



8" Rotary Pump
Model W8R - P404D22 Super Silent
Size 8" Rotary Pump

Holland® Pump Company
Corporate Office: 2610 Sidney Lanier Drive
Brunswick, Georgia 31525
Phone 912-466-0304
1-888-997-PUMP
www.hollandpump.com

PUMP SPECIFICATIONS

Size: 8" Rotary Pump

Pump: LobePro GL266, Class 30 gray cast iron casing and smooth end cover

Solids: Handles up to 2.5" soft solids

Rated Capacities: 1328 GPM (178) CFM @500 RPM

Displacement: 266 US gallons per 100 revolutions

Working Pressure: to 70 psi (over 25 psi requires larger engine)

Flange Connections: 8" Raised Face ANSI, 150 lbs. Flange connections included, stainless steel

Rated Speed: 0 - 500 RPM. Consult factory for recommended operating speeds

Rotors in: Helix four wing rotors, NBR standard, other materials available on request

Wet-Ends: ASTM A48 Class 30 grey iron

Shaft Material: Alloy Steel, AISI 4140

Gear Material: AGMA Class 8, SAE 1045

Gear Chamber: SAE 85W90 gear oil (3.0 quarts)

Quench Chamber: SAE 85W90 gear oil (3.5 quarts)

Mechanical Seals: Duronit vs. Duronit cartridge seal

Vibration: Pumps and motors operate at any point within their operating range without undue noise and vibration

Top and Bottom Housing Segments: ASTM A48 Class 30. Segments adjustable based on wear.

Optional Equipment: Site or DOT highway trailer, Instrument panel system with low vacuum shutdown system (LOV), automatic remote start/stop, HANS (Holland Automatic Notification System), sound enclosure.

SOUND ENCLOSURE SPECIFICATIONS

Sound Level: Holland Pump Supersilent pump units are tested for Sound Level using the Contractors Pump Bureau Sound Level Measurement Standard for Pump Units using a calibrated Sound Level Meter. This procedure produces an average Sound Level based on eight measurements under strict conditions of pump placement. They are tested at full RPM pumping water. The sound level result for the W8R-SS is 68 dBA @ 23 feet.

Enclosure: Steel construction, removable for ease of maintenance.

Stainless steel accessories including bolt on, lift off hinges.

Base: Environmentally safe spill containment type base

Lifting Access: External lifting bail, integral forklift pockets

GEAR SPECIFICATIONS

PTO Gear Reduction: 3.75 to 1

Gear oil: SAE85W90 (1.3 Quarts)

ENGINE SPECIFICATIONS

Model: Perkins, 400 Series, 404D-22, Tier 3

Type: 4 Cylinder, 4 Stroke, Naturally Aspirated, Liquid Cooled Diesel Engine

Displacement: 2.2L (134cu.in.)

Governor: Mechanical

Lubrications: Forced Circulation

Air Cleaner: Dry Type with Replaceable Element

Lube Oil Capacity: 2.8 U.S. gal (10.6 L)

Coolant Capacity: 1.84 U.S. gal (6.98 L)

Fuel Tank: Integral 68 U.S. Gallon Capacity (#2 Diesel Fuel)

Full Load Operating Time: 60 Hours Minimum

Starter: 12 Volt, 2.0 kW

Standard Features: SAE 4 Flywheel Housing and SAE 7-1/2" Flywheel, Standard Instrument Panel: Engine Temperature and Low Oil Pressure with optional Gauge, Key Start, and Hour Meter

Optional Features: Site or DOT Highway Trailer, Automatic Remote Start/Stop, HANS (Holland Automatic Notification System), NEMA 4 Instrument Package Covering: Air Filter, Fuel Filter, Engine Temperature, Fuel Level, Engine Oil Pressure, Hour Meter, Amp Meter, Low Vacuum Shutdown

Perkins Published Performance: 35 BHP (28.5kW) Continuous @ 2000 RPM



© Copyright by Holland Pump Company 2011

8" Rotary Pump
Model W8R - P404D22 Super Silent
Size 8" Rotary Pump

Holland® Pump Company
Corporate Office: 2610 Sidney Lanier Drive
Brunswick, Georgia 31525
Phone 912-466-0304
1-888-997-PUMP
www.hollandpump.com

Approximate Dimensions

Powered by Perkins 404D-22 Diesel Engine
System noise level @ 23': 75.8 DB Avg.*
Approx. Gross Weight: 5100 lbs.

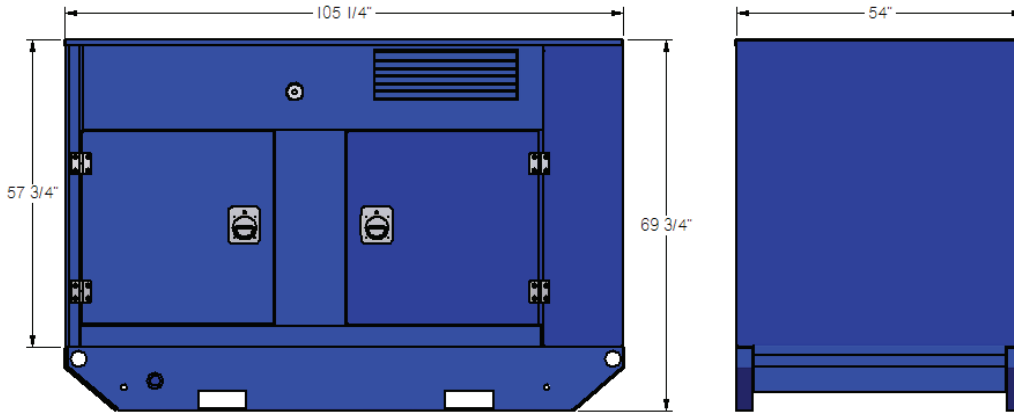

Performance Curve Model: W8R-P404D22
Size: 8" Rotary Pump

U.S. Gallons
Per Minute (GPM)
1600

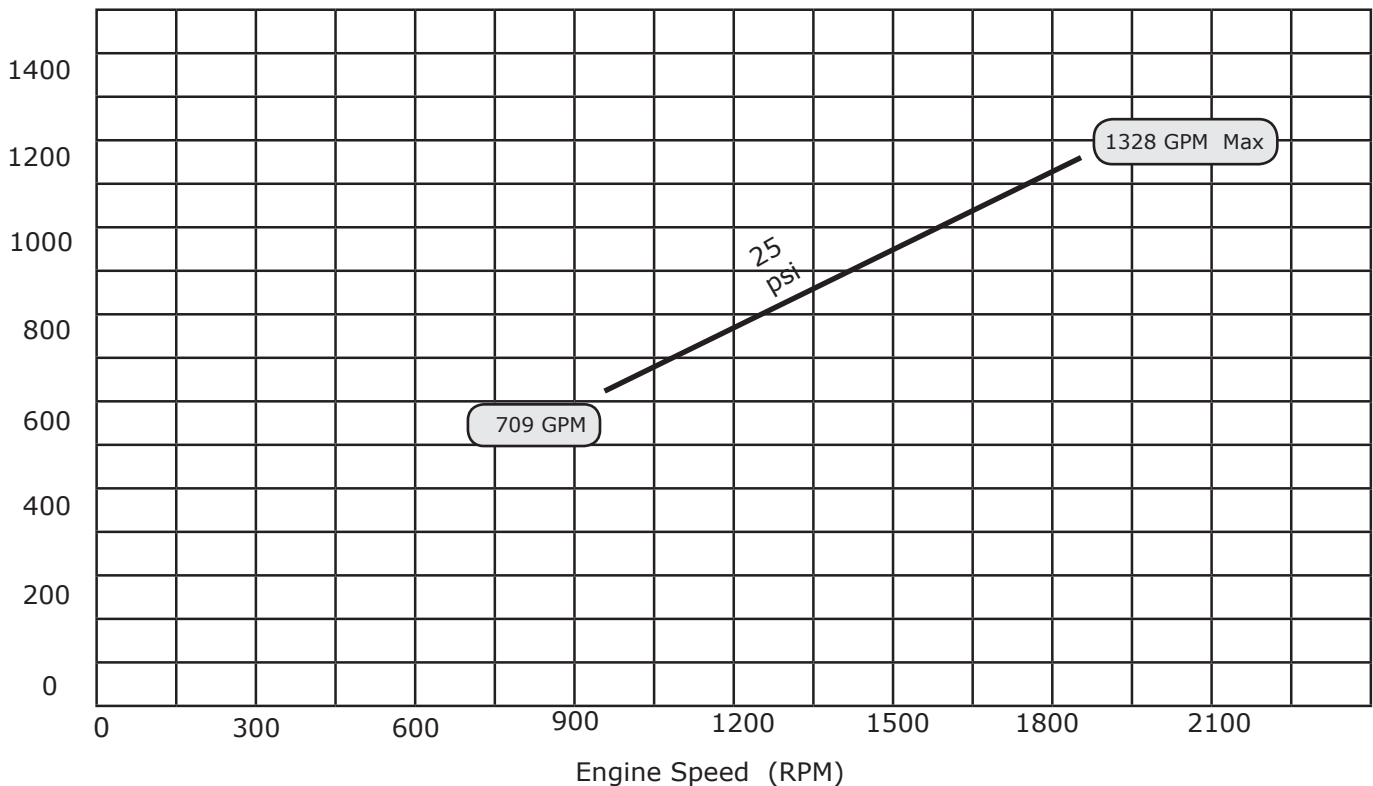

The above curve is based on pumping clear water at 62 degrees with no lift required and no restrictions in the discharge.

* Measured in open area on concrete surface using Contractor Bureau test method.