



© Copyright by Holland Pump Company 2011

8" Hydraulically Driven Submersible System
Model H8TP-D4045TF280-Super Silent
Size 8" Trash Pump

Holland® Pump Company
Corporate Office: 2610 Sidney Lanier Drive
Brunswick, Georgia 31525
Phone 912-466-0304
1-888-997-PUMP
www.hollandpump.com

PUMP SPECIFICATIONS

- Size:** 8" Trash Pump
- Volute:** Fabricated Steel (optional stainless steel and special abrasion resistant steel volutes are available)
- Impeller:** Semi-open, 3 Vane.
- Solids:** Handles 4" diameter compressible spherical solids.
- Impeller Shaft:** High strength steel
- Seal:** Rotary Mechanical, oil-lubricated, carbon & ceramic
- Hydraulic System**
- Hydraulic Reservoir level:** 50 gallon capacity with twin 10 micron spin on oil filter
- Hydraulic Oil:** Petroleum based AW68 Furnished standard
(optional canola bio-degradeable oil or mineral based non-toxic inherently bio-degradeable oil available)
- Hydraulic Pump:** Denison vane type positive displacement pump with pilot operated Denison relief valve
- Hydraulic Motor:** Vickers vane type positive displacement motor
- Heat Exchanger:** Double row, SCH 40 pipe with integral intake basket (optional engine mounted oil cooler available)
- Hydraulic Hose:** 50' set of SAE 100R2, two wire braid high-pressure hose
- Pump Head Pressure Relief System:** Available as option to protect system against improper connection or interruption of hydraulic oil flow from pump head to power unit

SOUND ENCLOSURE SPECIFICATIONS

- Sound Level:** Holland Pump Supersilent pump units are tested for Sound Level using the Contractors Pump Bureau Sound Level Measurement Standard for Pump Units using a calibrated Sound Level Meter. This procedure produces an average Sound Level based on eight measurements under strict conditions of pump placement. They are tested at full RPM pumping water. The sound level result for the H8TP is 71 dBA @ 23 feet.
- Enclosure:** Steel construction, removable for ease of maintenance.
Stainless steel accessories including bolt on, lift off hinges.
- Base:** Environmentally safe spill containment type base
- Lifting Access:** External lifting bail, integral forklift pockets

ENGINE SPECIFICATIONS

- Model:** John Deere 4045TF280, Tier 3
- Type:** 4 Cylinder, 4 Stroke, Turbocharged, Liquid Cooled Diesel Engine
- Displacement:** 4.5L (275 cu.in.)
- Governor:** Mechanical
- Lubrication:** Forced Circulation
- Air Cleaner:** Dry Type with Replaceable Element
- Lube Oil Capacity:** 3.5 U.S. gal (13.2L)
- Coolant Capacity:** 2.25 U.S. gal (8.5L)
- Fuel Tank:** Integral 114 U.S. Gallon Capacity (#2 Diesel Fuel)
- Full Load Operating Time:** 60 Hours Minimum @ 2000 PSI
- Starter:** 12 Volt, 2.0 kW
- Standard Features:** Cast Iron Engine Block, SAE Flywheel and Flywheel Housing, Ecoplus Oil and Fuel Filters, Glow Plug Starting Aid, Integral Inlet and Manifold, Gear Driven Coolant Pump, Cast Iron Exhaust Manifold with Center Side Outlet, Standard Instrument Panel: Engine Temperature and Low Oil Pressure with optional Gauge, Key Start, and Hour Meter
- Optional Features:** Site or DOT Highway Trailer, Automatic Remote Start and Stop, HANS (Holland Automatic Notification System), NEMA 4 Instrument Package Covering: Air Filter, Fuel Filter, Engine Temperature, Fuel Level, Engine Oil Pressure, Hour Meter, Amp Meter, Hydraulic Oil Pressure
- John Deere Published Performance:**

H8TP @ 2000 PSI	Capacity of Pump in U.S. Gallons per Minute (gpm) (Continuous Performance)
20' Head	2450
10' Head	2700

Maximum Continuous Power: 72 BHP (54kW) @ 2400 RPM
Maximum Intermittent Power: 80 BHP (60kW) @ 2400 RPM

Specifications subject to change without notice



© Copyright by Holland Pump Company 2011

**8" Hydraulically Driven Submersible System
Model H8TP-D4045TF280-SS
Size 8" Trash Pump**

Holland® Pump Company
Corporate Office: 2610 Sidney Lanier Drive
Brunswick, Georgia 31525
Phone 912-466-0304
1-888-997-PUMP
www.hollandpump.com

Approximate Dimensions: 105 1/4" x 69 3/4" x 54"
Powered by John Deere 4045 TF280 Diesel Engine
System noise level @ 23': 67 dBA*

Approx. Net Weight (lbs)

Skid Base
6500

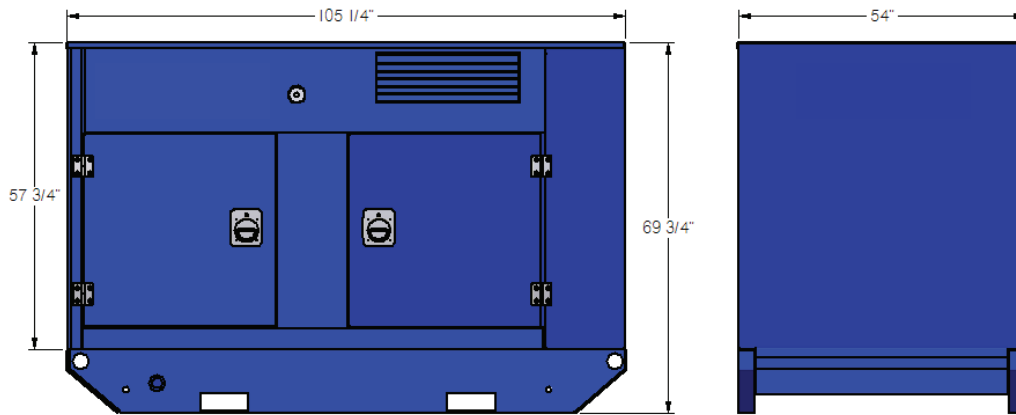

**Performance Curve Model: H8TP-D4045TF280-SS
Size: 8" Trash Pump**

TOTAL HEAD
PSI FT

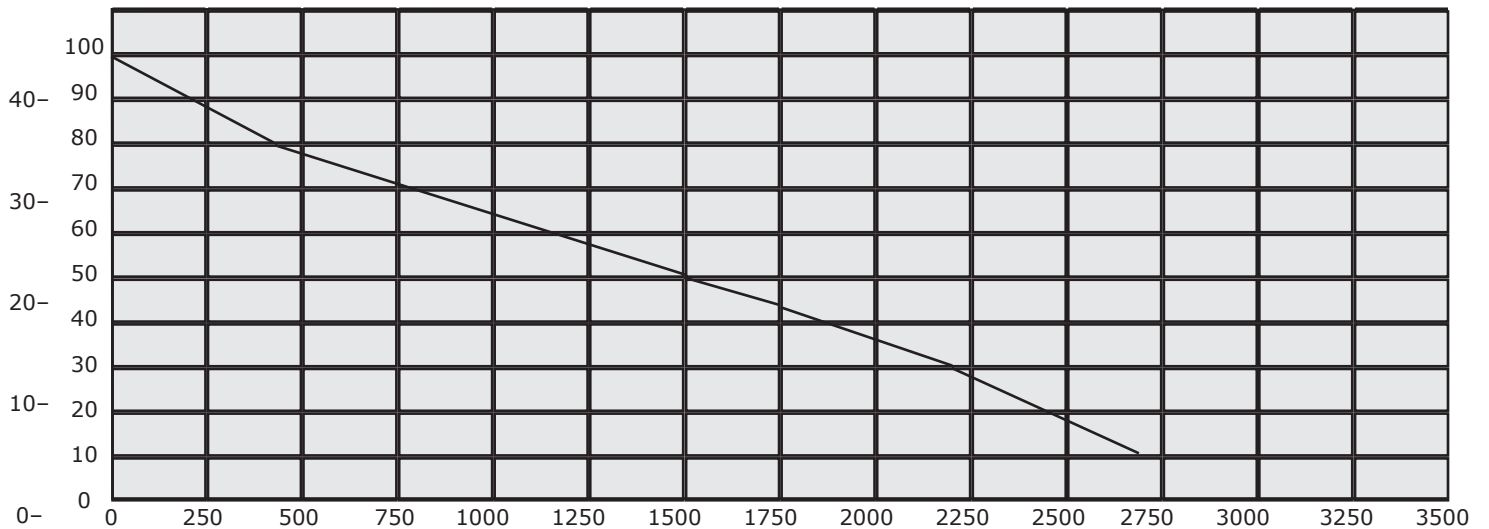

U.S. Gallons Per Minute (GPM) @ 2000 PSI