



© Copyright by Holland Pump Company 2011

PRIME³ Vacuum Assisted Suction Pump
 Model PT6TPC - D4045TF280
 6" High Head Trash Pump

Holland® Pump Company
 Corporate Office: 2610 Sidney Lanier Drive
 Brunswick, Georgia 31525
 Phone 912-466-0304
 1-888-997-PUMP
 www.hollandpump.com

PUMP SPECIFICATIONS

Type/Model: Solids handling/Cornell Redi-Prime High Head Pump

Volute: Fine gray cast iron

Flanges: 6" suction, 6" discharge

Impeller: 2 Vane enclosed impeller, steel

Solids: Handles 3" diameter compressible, spherical solids

PRIME³ Priming System: Automatic priming system that features a 50 cfm water tolerant, diaphragm vacuum pump driven by the main drive shaft. Our major competitors use a 15 cfm compressor pump with a small compressor venturi that can easily clog. The air/water separator is a simple, reliable stainless steel float that opens and closes a rubber plunger as water rises and falls. A non return valve isolates the pump during priming and protects against back flow

Discharge Valve: Val-matic or equal

Seal: Cornell patented Cycloseal® design with Run-Dry oil lubrication system. Single mechanical seal with Viton® elastomers, stainless steel hardware and tungsten versus silicon-carbide seal faces for abrasion

Shaft Sleeve: Heat treated 416 stainless steel

Bearings: Heavy duty, grease lubricated, deep groove ball bearings, with a minimum of 50,000 hours bearing life

PT6TPC-D4045TF280			Shutoff Head: 206 feet		
Flow (GPM)	Speed (RPM)	TDH (ft)	Pump Efficiency (%)	Power (hp)	Max Suction Head (ft)*
1398	1900	126	77	57.5	13.5
1165	1900	139	78	52.5	16.3
1126**	1900	141	79	50.6	17.1
932	1900	151	77	46.2	19.7
699	1900	167	73	40.2	22
466	1900	176	66	31.4	23

*Max Suction Head is suction lift plus friction losses without risk of suction cavitation
 **Best Efficiency Point

ENGINE SPECIFICATIONS

Model: John Deere 4045TF280, Tier 3

Type: 4 Cylinder, 4 Stroke, Naturally Aspirated, Liquid Cooled Diesel Engine

Displacement: 4.5L (276 cu.in.)

Governor: Mechanical

Lubrications: Forced Circulation

Air Cleaner: Dry Type with Replaceable Element

Lube Oil Capacity: 3.5 U.S. gal (13.2L)

Coolant Capacity: 2.25 U.S. gal (8.5L)

Fuel Tank: Integral 114 U.S. Gallon Capacity (#2 Diesel Fuel)

Full Load Operating Time: 60 Hours Minimum @ 2000 PSI

Starter: 12 Volt, 2.0 kW

Standard Features: Cast Iron Engine Block, Flywheel and Flywheel Housing, Ecoplus Oil and Fuel Filters, Glow Plug Starting Aid, Integral Inlet and Manifold, Gear Driven Coolant Pump, Cast Iron Exhaust Manifold with Center Side Outlet, Standard Instrument Panel: Engine Temperature and Low Oil Pressure with optional Gauge, Key Start, and Hour Meter

Optional Features: Auto-Oiler with Engine Oil Shutdown, Site or DOT Highway Trailer, Automatic Remote Start and Stop, HANS (Holland Automatic Notification System), NEMA 4 Instrument Package Covering: Air Filter, Fuel Filter, Engine Temperature, Fuel Level, Engine Oil Pressure, Hour Meter, Amp Meter

Coupling: Stromag coupling

John Deere Published Performance:

Maximum Continuous Power: 72 BHP (54kW) @ 2400 RPM

Maximum Intermittent Power: 80 BHP (60kW) @ 2400 RPM



© Copyright by Holland Pump Company 2011

PRIME³ Vacuum Assisted Suction Pump
Model PT6TPC - D4045TF280
6" High Head Trash Pump

Holland® Pump Company
Corporate Office: 2610 Sidney Lanier Drive
Brunswick, Georgia 31525
Phone 912-466-0304
1-888-997-PUMP
www.hollandpump.com

Approximate Dimensions

Powered by John Deere 4045TF280, Tier 3 Engine
Optional single axial trailer shown

	Skid Base	DOT Trailer
Net Weight (lbs)	2502	3510
Shipping Weight (lbs)	3300	N/A
Export Crate Size (cu. ft)	130	N/A

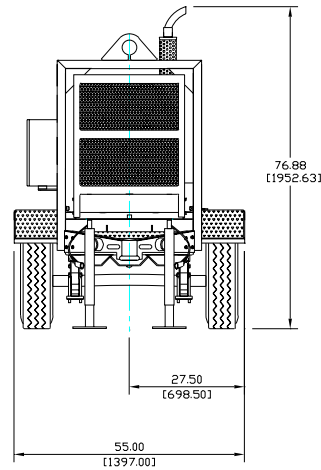
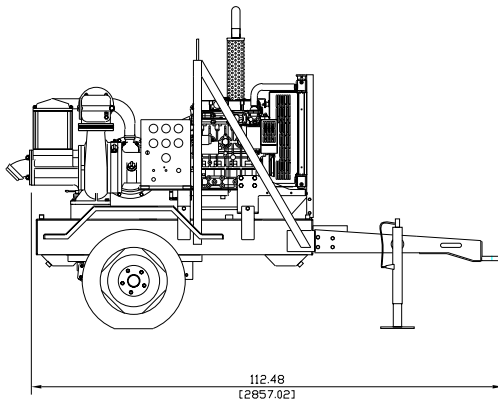

Performance Curve Model: PT6TPC - D4045TF280
6" High Head Trash Pump

SINGLE VOLUTE

MOUNTING CONFIG.: F, EM

