



© Copyright by Holland Pump Company 2011

**PRIME<sup>3</sup>** Vacuum Assisted Suction Pump  
Model PA3TPA - Y3TNV72  
Size 3" Trash Pump

Holland® Pump Company  
Corporate Office: 2610 Sidney Lanier Drive  
Brunswick, Georgia 31525  
Phone 912-466-0304  
1-888-997-PUMP  
www.hollandpump.com

**PUMP SPECIFICATIONS**

**Type/Model:** Solids and slurry handling, lower head pump/All Prime Model S-3  
**Volute:** Fine gray cast iron  
**Flanges:** 3" suction, 3" discharge  
**Impeller:** 8-3/4" Vane enclosed impeller, fine gray iron  
**Solids:** Handles 2.5" compressible, spherical solids  
**Discharge Valve:** not included  
**Seal:** Single mechanical seal  
**Shaft Sleeve:** Stainless steel  
**Bearings:** Heavy duty, grease lubricated, deep groove ball bearings, with a minimum of 50,000 hours bearing life

PA3TPA - Y3TNV72	Shutoff Head: 88 feet	
Suction Head (ft)	15'	15'
Max. Dist. to Water Level from Pump Suction Centerline (ft)	19'	19'
FLOW (GPM)	275	400
Total Dynamic Head (ft)	60	50
Fuel Consumption (U.S. Gal/Hr)	1.3	1.3
Speed (RPM)	1800	1800
Impeller Diameter (in)	8.75	8.75
Engine Cont. HP @ 1800 RPM	12.7	12.7
Pump Power at Duty Point (HP)	8.8	9.8

**ENGINE SPECIFICATIONS**

**Model:** Yanmar 3TNV72  
**Type:** 3 Cylinder, 4 Stroke, Naturally Aspirated, Liquid Cooled Diesel Engine  
**Displacement:** 0.9 L (55 cu. in.)  
**Governor:** Mechanical  
**Lubrication:** Forced Circulation  
**Air Cleaner:** Dry Type with Replaceable Element  
**Lube Oil Capacity:** 2 U.S. gal (7.6 L)  
**Coolant Capacity:** 2.5 U.S. gal (9.4 L)  
**Fuel Tank:** Integral 114 U.S. Gallon Capacity (#2 Diesel Fuel)  
**Full Load Operating Time:** 60 Hours Minimum  
**Starter:** 12 Volt, 2 kW  
**Standard Features:** Skid, SAE Flywheel Housing, SAE Flywheel, Murphy Safety Shutdown System Covering: Engine Oil Pressure, High Water Temperature  
**Optional Features:** Auto-Oiler with Engine Oil Shutdown, Auto-Start, HANS (Holland Automatic Notification System), Site or DOT Highway Trailer, Full Instrument Package  
**Coupling:** Stromag coupling

**Yanmar Published Performance:** Power: 24 BHP Continuous @ 3000 RPM



© Copyright by Holland Pump Company 2011

**PRIME<sup>3</sup> Vacuum Assisted Suction Pump**  
Model PA3TPA - Y3TNV72  
Size 3" Trash Pump

Holland® Pump Company  
Corporate Office: 2610 Sidney Lanier Drive  
Brunswick, Georgia 31525  
Phone 912-466-0304  
1-888-997-PUMP  
www.hollandpump.com

Approximate Dimensions  
Powered by Yanmor 3TNV72 Diesel Engine  
Optional trailer shown

	Skid Base	DOT Trailer
Net Weight (lbs)	3110	3510
Shipping Weight (lbs)	3300	N/A
Export Crate Size (cu. ft)	130	N/A

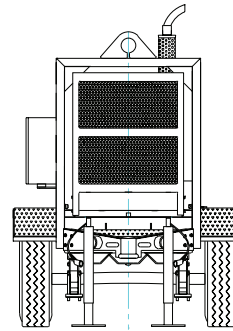
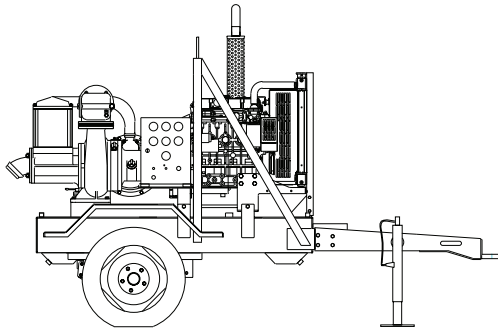

**Performance Curve Model: PA3TPA - Y3TNV72**  
Size: 3" Trash Pump

