



PRIME³ Vacuum Assisted Suction Pump
Model PT6TPC - E60
Size 6" High Head Trash Pump

Holland Pump Company
Corporate Office: 7312 Westport Place
West Palm Beach, FL 33413
1-800-451-0769
www.hollandpump.com

PUMP SPECIFICATIONS

Type/Model: Solids handling/Cornell Redi-Prime High Head Pump

Volute: Fine gray cast iron

Flanges: 6" suction, 6" discharge

Impeller: 2 Vane enclosed impeller, stainless steel

Solids: Handles 3" compressible, spherical solids

PRIME³ Priming System: Automatic priming system that features a 50 cfm water tolerant, diaphragm vacuum pump driven by the main drive shaft. Our major competitors use a 15 cfm compressor pump with a small compressor venturi that can easily clog. The air/water separator is a simple, reliable stainless steel float that opens and closes a rubber plunger as water rises and falls. A non return valve isolates the pump during priming and protects against back flow

Discharge Valve: Val-matic or equal

Seal: Cornell patented Cycloseal® design with Run-Dry oil lubrication system. Single mechanical seal with Viton® Elastomers, stainless steel hardware and tungsten versus silicon-carbide seal faces for abrasion

Shaft Sleeve: Heat treated 416 stainless steel

Bearings: Heavy duty, grease lubricated, deep groove ball bearings, with a minimum of 50,000 hours bearing life

PT6TPC-E60			Shutoff Head: 176 feet		
Flow (GPM)	Speed (RPM)	TDH (ft)	Pump Efficiency (%)	Power (hp)	Max Suction Head (ft)*
1296	1760	107	77	45.6	13.9
1080	1760	118	78	41.3	19.1
1037**	1760	120	79	39.8	19.9
864	1760	130	77	37	23
648	1760	142	73	31.7	23
432	1760	151	64	25.2	23
*Max Suction Head is suction lift plus friction losses without risk of suction cavitation					
**Best Efficiency Point					

ENGINE SPECIFICATIONS

Motor: Severe duty premium efficient 60 Hp 230/460 VAC 3 phase

Control: Standard across the line Starter, soft start - optional VFD, variable voltage, NEMA 4X, Explosion proof



© Copyright by Holland Pump Company

Holland Pump Company
Corporate Office: 7312 Westport Place
West Palm Beach, FL 33413
1-800-451-0769
www.hollandpump.com

PRIME³ Vacuum Assisted Suction Pump
Model PT6TPC - E60
Size 6" High Head Trash Pump

Approximate Dimensions
Powered by 60 HP Electric Motor

	Skid Base	DOT Trailer
Net Weight (lbs)	3110	3510
Shipping Weight (lbs)	3300	N/A
Export Crate Size (cu. ft)	130	N/A

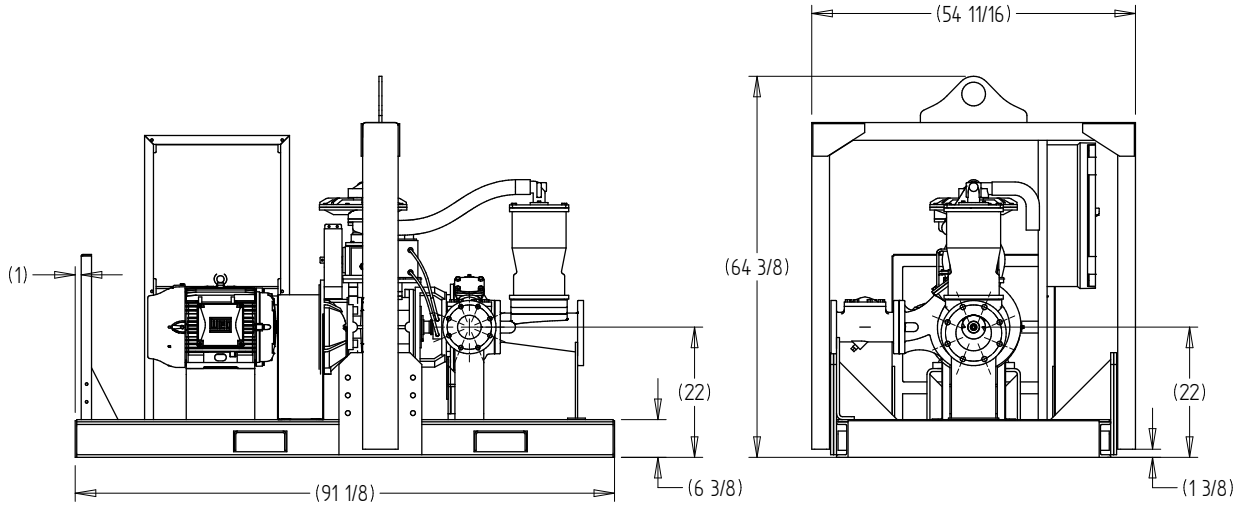

Performance Curve Model: PT6TPC - E60
Size: 6" High Head Trash Pump

