



© Copyright by Holland Pump Company

PRIME³ Vacuum Assisted Suction Pump
Model PT6TPA - E40
Size 6" Trash Pump

Holland Pump Company
Corporate Office: 7312 Westport Place
West Palm Beach, FL 33413
1-800-451-0769
www.hollandpump.com

PUMP SPECIFICATIONS:

Type/Model: Solids handling/Cornell Redi Prime

Volute: Cast iron ASTM A48 class 30

Flanges: 6" suction, 6" discharge

Impeller: Non-clogging, balanced, 2 vane, 10.09" diameter, enclosed

Solids: Handles 3" diameter compressible, spherical solids

PRIME³ Priming System: Automatic priming system that features a 50 cfm water tolerant, diaphragm vacuum pump driven by the main drive shaft. Our major competitors use a 15 cfm compressor pump with a small compressor venturi that can easily clog. The air/water separator is a simple, reliable float that opens and closes a rubber plunger as water rises and falls. A non return valve isolates the pump during priming and protects against back flow

Wear Rings: Replaceable (Double wear rings available)

Seal: Cornell's patented Cycloseal® design with Run-Dry oil lubrication system. John Crane T-2 single mechanical seal with Viton® elastomers, stainless steel hardware and tungsten- vs. silicon carbide seal faces for abrasion resistance

Discharge Valve: Val-matic or equal

Shaft Sleeve: Heat treated 416 stainless steel

Bearings: Heavy duty, grease lubricated, deep groove ball bearings, with a minimum of 50,000 hours bearing life

PT6TPA-E40			Shutoff Head: 121 feet		
Flow (GPM)	Speed (RPM)	TDH (ft)	Pump Efficiency (%)	Power (hp)	Max Suction Head (ft)*
1248	1770	48.9	59	26.3	13.7
1040	1770	65.3	71	24.4	20.6
832	1770	77.1	76	21.4	23
768**	1770	80.3	76	20.4	23
624	1770	87.1	74	18.4	15.6
416	1770	96.7	68	15	18.9

*Max Suction Head is suction lift plus friction losses without risk of suction cavitation
**Best Efficiency Point

MOTOR SPECIFICATIONS

Motor: Severe duty premium efficient 40 Hp 230/460 VAC 3 phase

Control: Standard across the line Starter, soft start - optional VFD, variable voltage, NEMA 4X, Explosion proof



© Copyright by Holland Pump Company

Holland Pump Company
Corporate Office: 7312 Westport Place
West Palm Beach, FL 33413
1-800-451-0769
www.hollandpump.com

PRIME³ Vacuum Assisted Suction Pump
Model PT6TPA - E40
Size 6" Trash Pump

Approximate Dimensions
Powered by 40 HP electric motor

	Skid Base	DOT Trailer
Net Weight	2600	2900
Shipping Weight	2700	N/A
Export Crate Size	119	N/A

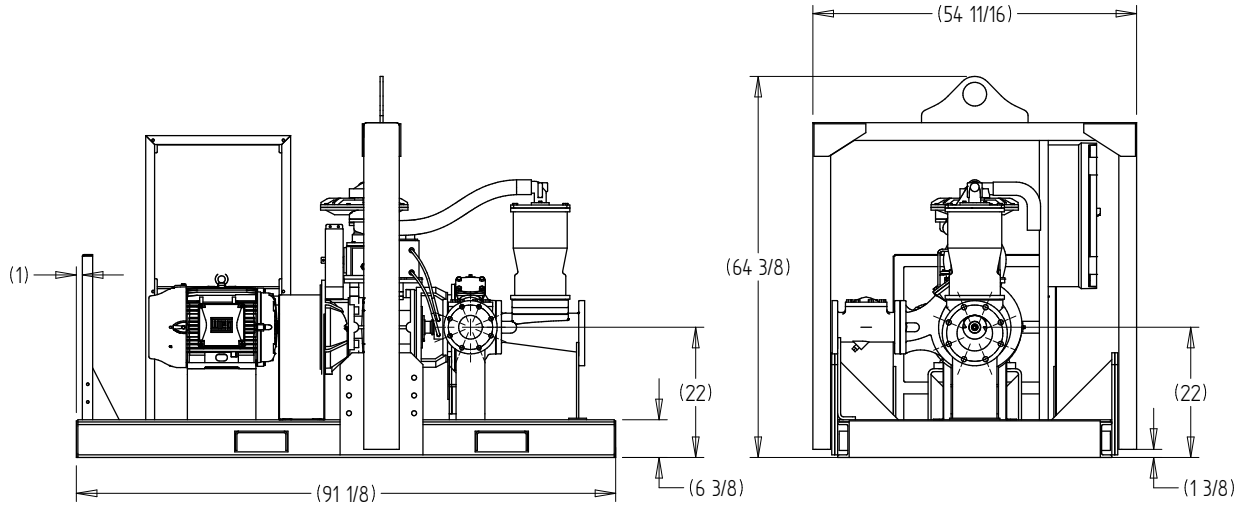

Performance Curve Model: PT6TPA- E40
Size: 6" Trash Pump

